

LLIA90 LED Illuminator Array

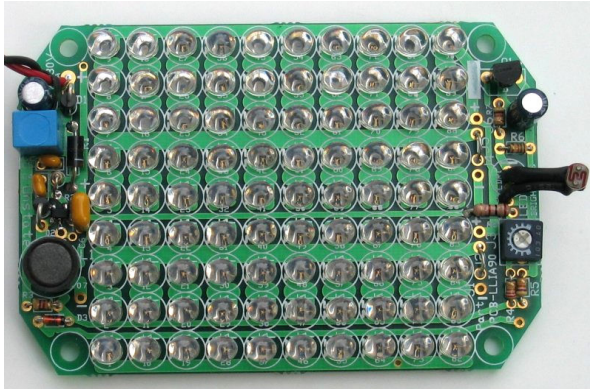

The LLIA90 is a high-quality and high-performance multi-purpose LED illuminator array. It has a built-in regulator and a photocell control circuit for automatic LED array on/off during the day and night. The LED array has 90 LEDs in 3 banks of 3-series and 10-parallel pattern. It can also be externally triggered on/off for multi-coloured illumination using red, green and blue arrays. The LEDs are current regulated to maintain best performance and to prevent thermal runaway from excess heat and voltage. The LLIA90 PCB is designed for high-performance LED illumination applications using thick copper pads on a double-sided

and through-hole plated design for high reliability and optimum LED heatsinking and performance. The solder pads are gold immersion coated for high soldering reliability and for RoHS compliance. The multi-purpose design features adjustable current control, high-efficiency switch-mode regulation, external trigger and auto photocell-triggered LED illumination for décor lighting or area lighting. The LED controller is also configurable to power other star-type, high-power star LEDs such as the Luxeon or K2 types.

Features:

- 90 LED illumination array for 5mm LEDs
- 3 banks at 3-series by 10-parallel pattern or 3x30 pattern
- Compact, small design.
- Adjustable current regulator
- Efficient, integrated switch-mode design
- 7-30VDC input, 1A output operation
- External or automatic photocell on/off control
- High performance design for LED applications
- Large copper pads for heat dissipation

Benefits:

- Maximise and maintains peak LED performance
- Extends LED life
- Efficient and low cost illumination

Applications:

- Portable lighting, architectural lighting
- Décor lighting, area lighting
- Replace light bulb lighting
- Configurable for external LED/electronic uses



The LLIA90 LED illuminator mounted inside a cabinet for décor lighting. The power supply can be connected to a power switch for manual on/off operation.

Dimensions:

All holes are 1/8" diameter at 2.0" x 2.75" spacing.

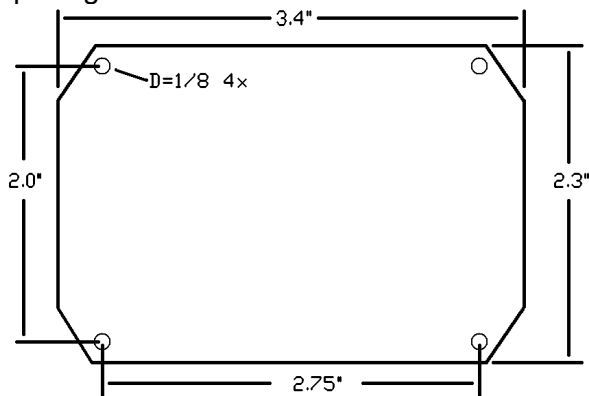

Do not exceed the specifications of the unit.

Technical Specifications:

Printed circuit board:

Thickness:	1/16"
Material:	FR4 glass fibre
Plating:	2 oz copper
Layers:	Double-sided
Finish:	Gold immersion
Soldermask:	Green both sides
Silkscreen:	White on component side
Routing:	Tabbed. 8pcs/pallet
Dimension:	3.4" x 2.3" rectangular
Soldering:	Through-hole plated
Compliance:	ROHS, lead-free

LLIA90 LED array:

Temperature:	-30°C to 50°C
Input voltage:	7-30VDC
LED:	5mm type, 90 total. 3 banks (3s10p)
Maximum current:	1A through LED driver
Maximum power:	10W total

Operation:

The DC input goes through the diode then to the ZXLD1360 buck-mode switching LED driver with a filtered current sensing shunt and a power inductor for LED current regulation. The IC adjust pin sets the LED current limit and LED power on/off control. A shunt voltage reference and variable resistor control sets the current limiting voltage range. The light dependent resistor (LDR) sensor connected to a NPN transistor grounds the IC adjust pin to set the automatic LED on/off control. The photocell operation can be adjusted by varying the matching resistor and delay capacitor. The jumpers (J1-J6) set the LED series pattern from 3, 6 or 9 series connection. Do not exceed 10W or put the illuminator inside a sealed plastic box due to the LED array will get hot at high currents. See ZXLD1360 data sheet and schematic for more information.

Installation:

Please read the appropriate data sheet prior to installation for best results. The installation should be made by a person knowledgeable in the product and conforms to all appropriate local codes. Onstate Technologies Inc. will not be responsible for injuries or damages resulting from the improper installation or use of any products sold by Onstate or its retailers. Install the product within its specification limits.

Maximise airflow to LED array for best performance. The LED array and components get warm during operation. Do not install in an enclosed area or expose to high temperatures. LEDs are sensitive to heat and static. If the LED array is using full power in a confined location, use the appropriate heatsink and heat transfer pad (gap filler). Use proper care during soldering and assembly. Follow the schematic and labels on the circuit board for quick and easy installation.

Product assembly:
1. LED array only.

Insert the LEDs in the pattern as on the PCB label. The LEDs are internally connected in series of threes. The selection of the jumpers connects each 3-series banks into a 3, 6 or 9 array. If a 6-series array is used, connect J2 and J6. The remaining 3-series bank is not used. For a 3-series bank array, connect jumpers J1, J3, J4 and J6. A 9-LED series array uses J2 and J5. Insert the LEDs in the quantity required. Add wire jumper from IC GND (pin 2) to Q2 center pin for LED array ground power. An external LED controller is recommended for safe and proper LED operation. A current limiting resistor maybe used if the input voltage is regulated and constant. Match the limiting resistor R1 for the correct current and voltage operation. Limiting resistors could also be used at jumper locations. Make sure that the power ratings of the resistor and LEDs are not exceeded at the maximum operating conditions. See LLIA90 schematic for more information.

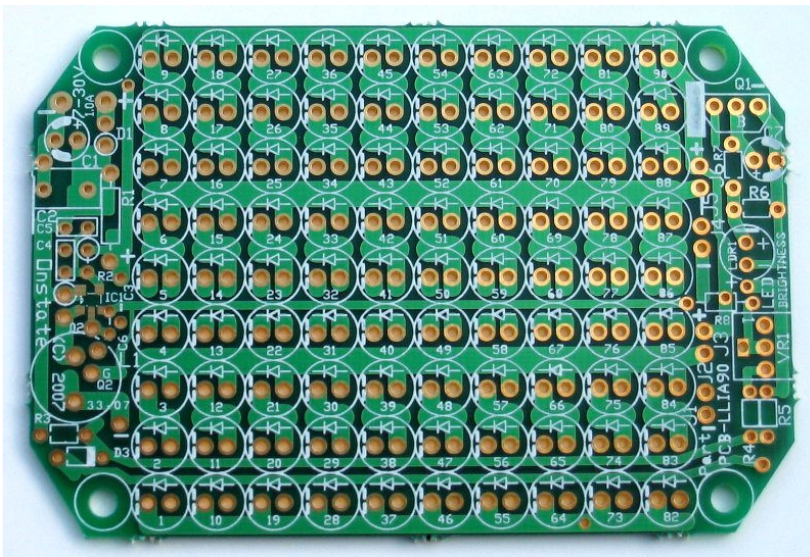

LLIA90 LED array label layer

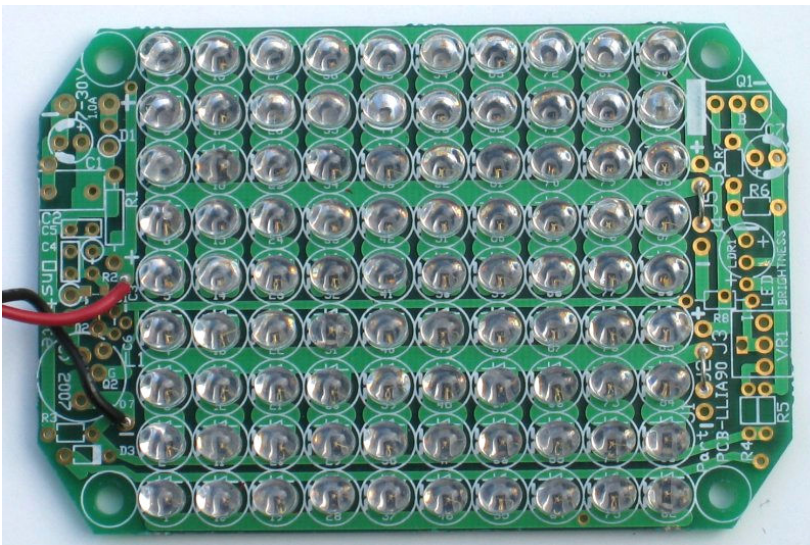

LLIA90 LED array with LEDs only. An external current limited controller is recommended for the LED array.

2. LLIA90 with LED driver and photocell.

Understand the parts as listed on the BOM and schematic. Insert LEDs for the LED array pattern required as recommended on the *LED array only* section. Test the LED array for proper operation before proceeding to solder the LED controller section. Solder IC1 first before soldering the remaining LED driver parts. Do not connect LED – and + connections to input power. The photocell circuit without LDR1 can accept an external DC voltage for LED array on/off control.

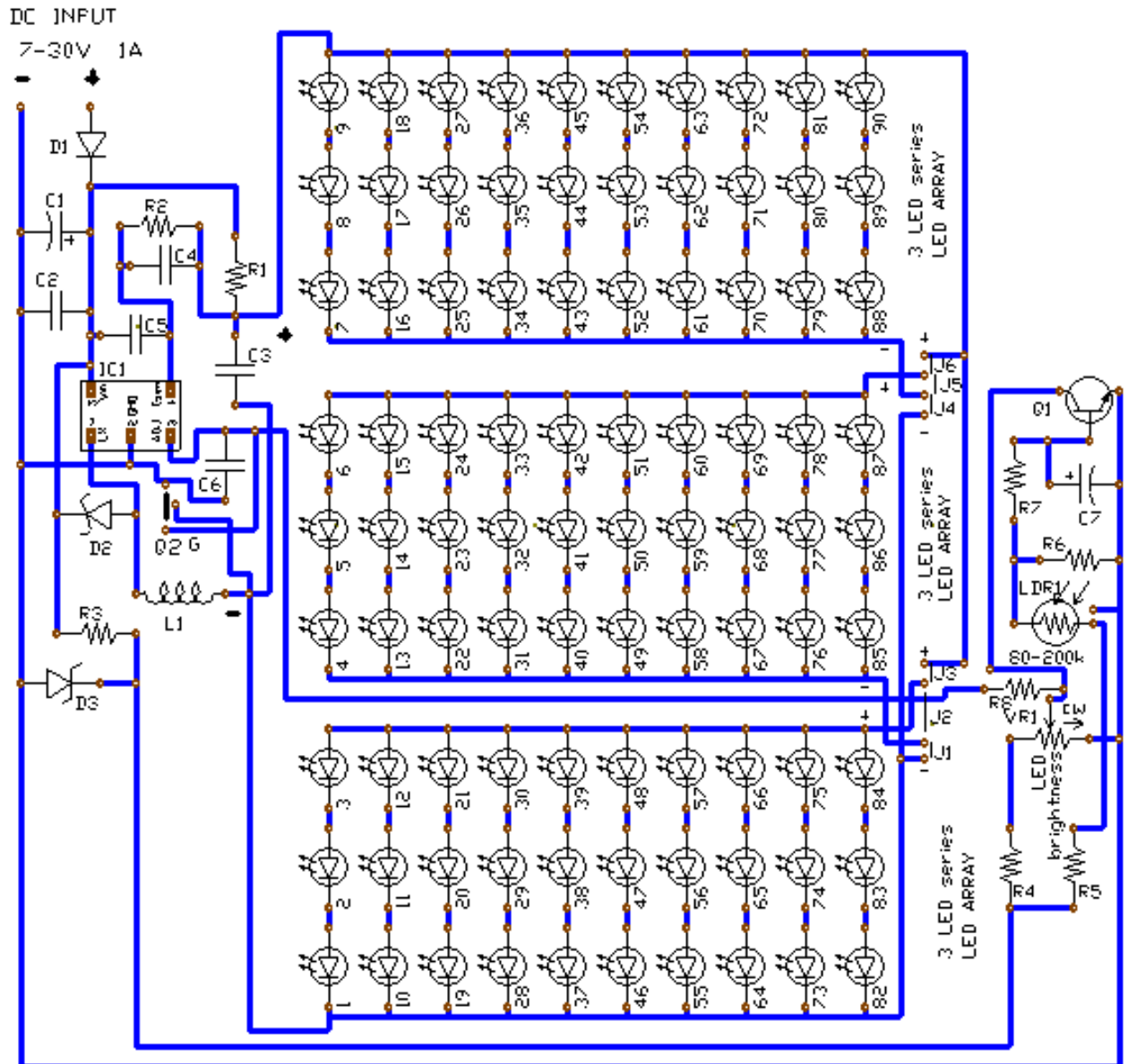

LLIA90 schematic. Bypass R4 for external LED array brightness signal control. Control signal is reference to DC input ground. Input $0.2V$ into the IC1 adjust pin is array off. $0.2-2.0V$ is LED array brightness. $1.25V$ signal is 100% intensity (1.0A) using a 0.1 ohm shunt resistor (R1). Note: move C6 to pin 1&3 of Q1. Do not exceed 1.0A for continuous use.

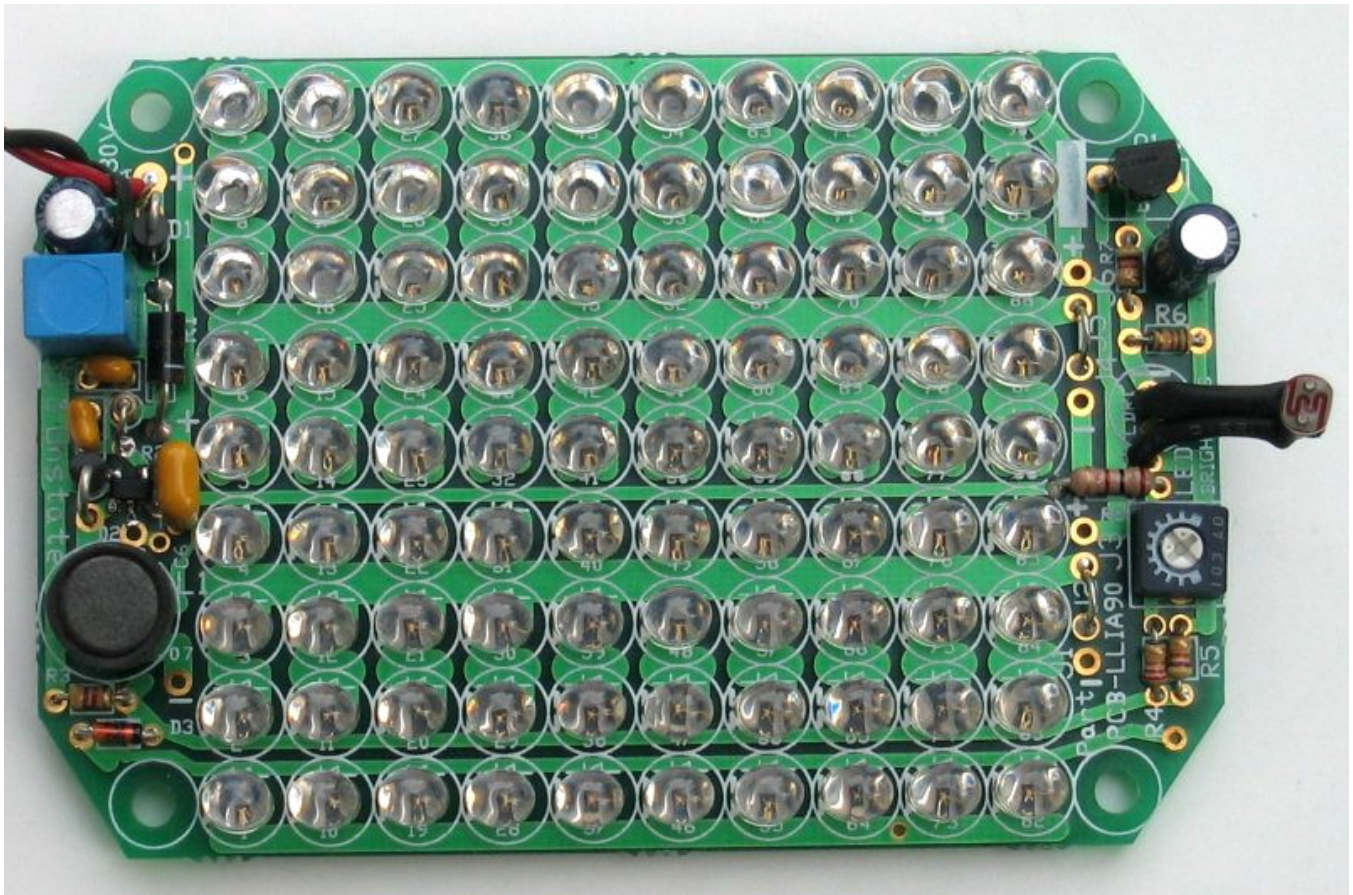

Fully assembled LLIA90 LED illuminator array.

Control Adjustments:

1. VR1 adjusts LED brightness current from off (<0.2V) to ~1.0A. R4 sets maximum current limit. R1 sets maximum shunt current (I_{sense} for IC1). R1 at 0.1 ohms is 1.0A nominal current.
2. The photocell circuit controls a NPN transistor for LED ON/OFF control. R5, R6 and photocell (LDR1) sets light level trigger.
3. The best method to measure LED array current is through the shunt resistor (R1). $Current = V_{drop} / R_{R1}$ Another method is to correlate the LED array voltage against a plot of the voltage Vs current graph. Make sure that the LED array temperature is at similar operating conditions.
4. The LED array will get hot at high operating currents, check current and temperature before installation. A heatsink and heat transfer pad may be required.

Bill-of-Materials for LLIA90 LED array with controller and photocell operation.

Part	Application	Description	Digi-Key #
R1	LED -, regulator current shunt feedback.	Resistor, 0.10 Ohms, 1/2W	WLAR100FECT-ND
R2	regulator current shunt feedback filter	Resistor, 100 Ohms, 1/8W 5% carbon film	100EBK-ND
R3	Zener shunt ref. limiting resistor	Resistor, 4.7k Ohms, 1/8W 5% carbon film	4.7KEBK-ND
R4	VR1, max current adjustment limiting	Resistor, 27k Ohms, 1/8W 5% carbon film	27KEBK-ND
R5	PC trigger adjustment limiting	Resistor, 47k Ohms, 1/8W 5% carbon film	47KEBK-ND
R6	PC trigger adjustment limiting divider	Resistor, 15K Ohms, 1/8W 5% carbon film	15KEBK-ND
R7	NPN base current limiter, PC delay	Resistor, 47k Ohms, 1/8W 5% carbon film	47KEBK-ND
R8	Regulator adjust filter/limiter	Resistor, 100 Ohms, 1/8W 5% carbon film	100EBK-ND
C1	input capacitor filter	Capacitor, 35V 47uF, electrolytic, 0.1"	P5164-ND
C2	input bypass capacitor filter	Mylar 1.0uF 63V metal film, 0.2" spacing	3019PH-ND
C3	LED bypass ripple filter	50V 1.0uF mono. cap, 0.2" spacing	BC1168CT-ND
C4	sense shunt filter	50V 0.22uF mono. cap, 0.1" spacing	use BC1103CT-ND
C5	sense shunt filter	50V 0.01uF mono. cap, 0.1" spacing	BC1158CT-ND
C6	IC adjust pin filter, insert on Q1 pads 1/3	50V 0.1uF mono. cap, 0.2" spacing	BC1165CT-ND
C7	photocell delay capacitor filter	Capacitor, 35V 47uF, electrolytic, 0.1" spacing	P5164-ND
D1	input diode protection	Diode, 1N4001 / 1N5819, 40V 1A	1N5819-E3/51GI-ND
D2	inductor clamping diode protection	Diode, 1N5819, 40V 1A	1N5819-E3/51GI-ND
D3	PC and LED current zener reference voltage	Zener, 1N5234, 6.2V, 500mW	1N5234BDICT-ND
IC1	LED controller switch	ZXLD1360, integrated LED controller	ZXLD1360ET5CT-ND
VR1	LED current limiting adjustment	Resistor, 10k variable, 3362U, top adjust, inline	3362U-103LF-ND
PC1	photoresistor, 80-200k	LDR sensor, 80-200k @10lux. 4.2mm, 5M dark	PDV-P9006-ND
L1	power inductor	power inductor, 100uH, 1.4A, radial	M8628-ND
Q1	NPN transistor, low power, PC on/off control	2N3904, NPN, TO-92	2N3904FS-ND
Q2	N-CH MOSFET, ext. IR on/off when not using LED controller.	N-CH MOSFET, IRFZ*, TO-220, not used	IRFZ*
PCB	LED array board, 90 LED	PCB, 90 LED illuminator array, V1	PCB-LLIA90
J1-J6	jumpers, 3/6/9 series connections	wire jumper	
LED1-LED90	5mm LEDs	5mm LEDs, white. Any 5mm LED.	
	Resistor, 10 ohms 1W for 12V input. One per bank.	Array using resistor limiting only. DC input. ~250-300mA	10W-1-ND

Application sample:

Décor lighting for cabinet with white LEDs. Also works well as a night-light or outdoor landscape light.

Parts:

1x PCB-LLIA90 and driver parts.

90x white or other coloured LEDs.

1x project box, metal preferred.

1x terminal strip.

1x 5mm LED holder.

1x 12-24VDC 1A AC/DC wall power supply.

Various mounting screws.



The LLIA90 LED illuminator mounted inside a cabinet for décor lighting. The power supply can be connected to a power switch for manual on/off operation.

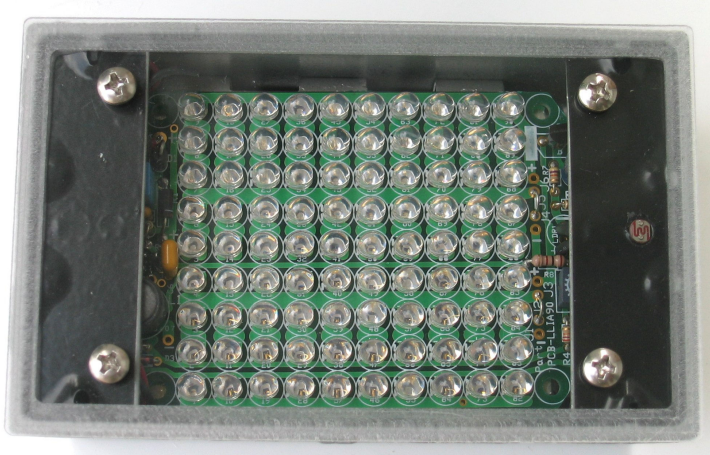

The LLIA90 LED illuminator mounted inside an outdoor die-cast metal electrical enclosure with Onstate window and hardware accessories. The photocell provides automatic on/off operation for landscape or area lighting.

