

PCR LED Controller

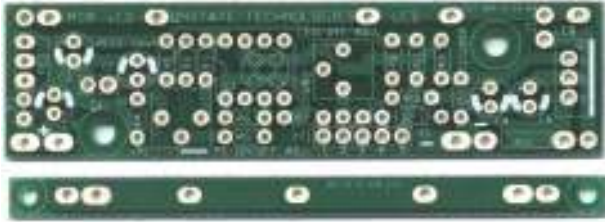

The PCR is a high-quality, multi-purpose LED controller with photocell and current regulator PCB for LED lighting applications. It has a photocell and a linear LED current regulator circuit to automatically control a LED array for day/night operation. The PCB is a double-sided and through-hole design using thick copper pads for high reliability and performance.

Features:

- Compact size
- through-hole, double-sided PCB
- thick copper traces and pads (silver plating)
- High performance design for LED applications
- Bus trace lines for LED power connections.
- Mounting holes
- Multi-purpose, integrated design

Benefits:

- Reduce design and assembling time.
- Extends LED life.

Applications:

- Landscape and area lighting
- LED controller
- Replace old photocell/LED controllers.
- Configurable for external LED/electronic uses

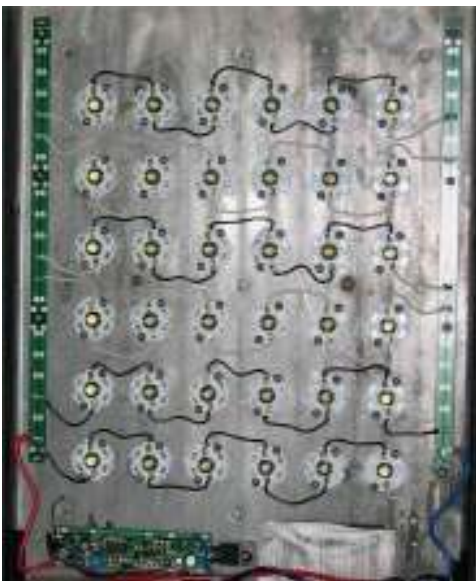

PCR module connected to LED array.
 Auto on/off and LED current regulator.

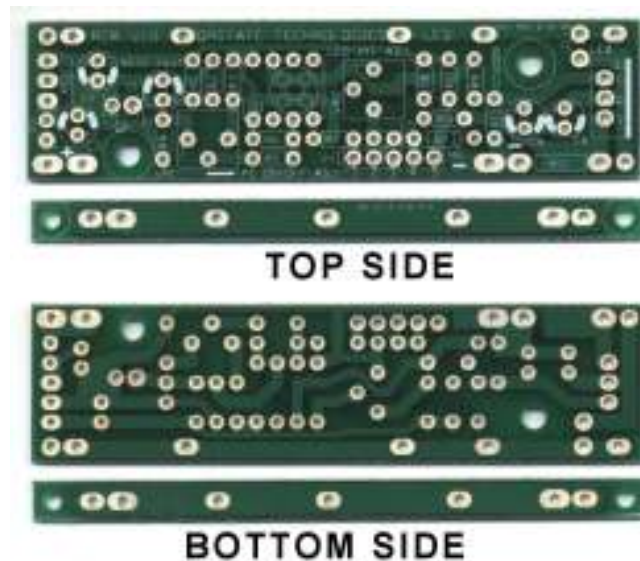

Top and bottom sides of PCR PCB.
 Detachable bus bar for LED connections.

Technical Specifications:

Printed circuit board:

Thickness:	1/16"
Material:	FR4 glass fibre
Plating:	2 oz copper
Layers:	Double-sided
Finish:	Silver-plating
Soldermask:	Green both sides
Routing:	V-Scored

Dimension:	PCB- 3.8"x0.82" Bus bar-3.8"x0.22"
Weight:	6 grams (0.21 Oz)
Soldering:	Through-hole plated
Mounting hole:	2x0.15", 2x 0.1" holes.
Compliance:	ROHS, lead-free power

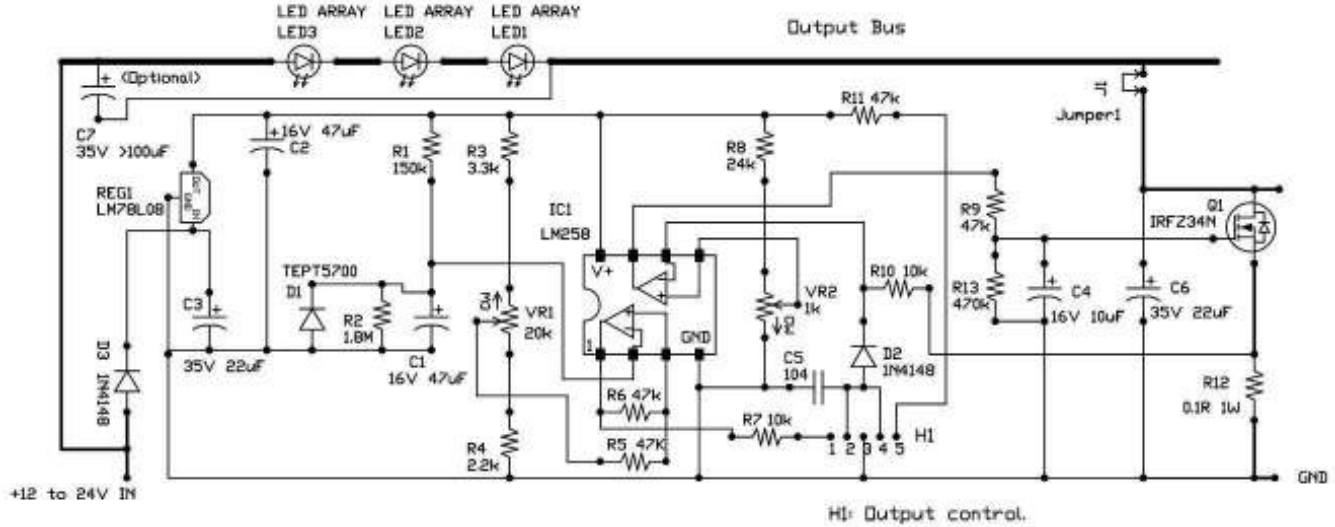
PCR Design

VR1: Photocell on/off control. 6.95-0.81V. VR2: LED current control.
 All resistors are 1/8W at 0.2" spacing. All capacitors are 0.1" spacing.
 H1: Pins ½ for AUTO mode. Pins ¾ for LED ON. Pins 4/5 for LED OFF.

Line	Part	Qty.	Description	Manufacturer	Man. Part Number
1	R1	1	Resistor, 150k Ohms, 1/8W 5% carbon film	Yageo	CFR-12JB-150K
2	R2	1	Resistor, 1.8M, 1/8W 5% carbon film	Yageo	CFR-12JB-1M8
3	R3	1	Resistor, 3.3k, 1/8W 5% carbon film	Yageo	CFR-12JB-3K3
4	R4	1	Resistor, 2.2k, 1/8W 5% carbon film	Yageo	CFR-12JB-2K2
4	R5,R6,R9	3	Resistor, 47k, 1/8W 5% carbon film	Yageo	CFR-12JB-47K
5	R7,R10,R11	3	Resistor, 10k, 1/8W 5% carbon film	Yageo	CFR-12JB-10K
5	R8	1	Resistor, 24k, 1/8W 5% carbon film	Yageo	CFR-12JB-24K
6	R12	1	Resistor, 0.10 Ohm, 1W 1% wirewound, mini	Ohmite	WHBR10FET
7	R13	1	Resistor, 470k, 1/8W 5% carbon film	Yageo	CFR-12JB-470K
8	C1,C3,C4	3	Capacitor, 16V 47uF, Ø6.3x7Lx2P mm, electrolytic	Panasonic	ECE-A1CKG470
9	C2,C4,C6	3	Capacitor, 35V 22uF, Ø6.3x7Lx2P mm, electrolytic	Panasonic	ECE-A1VKG220
10	C5	1	Capacitor, 50V 0.1uF (104), 0.1" ceramic X7R 10%	Vishay/BC Components	K104K15X7RF5TL2
11	D1	1	Transistor, TEPT5700, photo 570nm light sensor, T 1-3/4	Vishay	TEPT5700
12	D2, D3	2	Diode, 1N4148T, Si 100V 0.2A, 500mW DO-35	Fairchild	1N4148
13	REG1	1	Regulator, LM78L08, 8V 100mA, TO-92	On Semi.	MC78L08ABPG
14	IC1	1	IC, LM258, dual op-amp, 8-pin DIP	On Semi.	LM258N
15	VR1	1	Resistor, 20k, 1/4" cer pot, top adj.	Bourns	3362R-1-203LF
16	VR2	1	Resistor, 1k, 1/4" cer pot, top adj.	Bourns	3362R-1-102LF
17	Q1	1	MOSFET, IRFZ44Z N-HEXFET, 55V 51A 0.0139 Ohm, TO-220AB	International Rectifier	IRFZ44ZPBF
18	J1	1	22 AWG bare jumper		
19	J2	1	22 AWG bare jumper, 2-pin jumper header		
20			H1: pin #1 and pin #2.		
	H1	1	Optional, connector, 1X5 header		

All parts are available from Digi-key (www.digi-key.com).